

THE SUM-OF-DIGITS FUNCTION FOR COMPLEX BASES

PETER J. GRABNER, PETER KIRSCHENHOFER
AND HELMUT PRODINGER

Dedicated to Professor Edmund Hlawka on the occasion of his 80th birthday

ABSTRACT

We consider digital expansions with respect to complex integer bases. We derive precise information about the length of these expansions and the corresponding sum-of-digits function. Furthermore we give an asymptotic formula for the sum-of-digits function in large circles and prove that this function is uniformly distributed with respect to the argument. Finally the summatory function of the sum-of-digits function along the real axis is analyzed.

1. Introduction

Positional number systems have been studied in many different contexts and a wealth of results are known about digital expansions of integers with respect to different bases. The sum-of-digits function $v_q(n)$ for the q -adic digital expansion admits an exact summation formula (cf. [2])

$$\sum_{n < N} v_q(n) = \frac{q-1}{2} N \log_q N + N F_q(\log_q N),$$

where F_q is a continuous, 1-periodic, nowhere differentiable function with known Fourier expansion. Several more sophisticated digital functions have been studied since then and the fractal behaviour of the summatory functions appeared in many of these cases (cf. [5, 23]).

Various methods were used to derive such summation formulæ: an early one was developed by Delange [2] and is based on reinterpretation of the occurring sums as real integrals. In [23] and [5] it is observed that the classical technique of Dirichlet generating functions can be used to derive Delange's formula.

In this paper we shall generalize some results about 'ordinary' digital expansions to positional number systems of the Gaussian integers, which were introduced by Knuth [20] and extensively studied by Gilbert in a series of papers [7–15]. Again fractal structures are involved, but it requires some additional ideas to use the techniques mentioned above in the case of complex bases.

In the introductory Section 2 we shall present a number of auxiliary results about digital expansions of complex integers (some of which recall results of Gilbert using a different approach). We also exhibit automata, which describe addition of 1 (respectively, other fixed Gaussian integers) in these positional number systems. Furthermore formulæ for the sum-of-digits function with respect to complex bases are derived and we analyze the length of the expansion asymptotically.

Received 24 August 1995; revised 11 October 1995.

1991 *Mathematics Subject Classification* 11A63.

The authors are supported by the Austrian-Hungarian science cooperation project 10U3 and by the Austrian National Bank project Nr. 4995. The first author is supported by the Schrödinger scholarship J00936-PHY.

In Section 3 we study the asymptotic behaviour of the summatory function of the complex sum-of-digits function in large circles, where we encounter quite similar behaviour as in the real case. In the sequel we use a technique similar to the proof of Hecke's prime number theorem to study the uniform distribution of the sum-of-digits function with respect to the argument.

In a final Section 4 we consider the summatory function of the sum-of-digits function along the real axis. We are able to give the order of magnitude of this function in the instance $b = -a + i$, where a is an even positive integer, but the correct asymptotics resisted our attempts, although there is some numerical support for the existence of an asymptotic main term. In the special case of the base $b = -1 + i$ we could derive an exact formula, which is quite similar to the real case. This is due to the fact that this base is 'quite close' to a real base ($b^4 = -4$). For a more detailed discussion of the difficulties occurring in the general case we refer to the section in consideration.

2. Some preliminary results

In this section we summarize a number of results on the $(-a+i)$ -ary representation ($a \in \mathbb{N}$) of Gaussian integers that will be helpful in the sequel or are of their own interest. Notice that these are the only complex integer bases, which give rise to a unique finite digital representation of the Gaussian integers using a 'connected' set of digits from the natural numbers (in our instance we have the digits $0, \dots, a^2$), cf. [18, 19]. We shall use the notation $(\varepsilon_k, \varepsilon_{k-1}, \dots, \varepsilon_0)_{-a+i}$ for the number

$$\sum_{l=0}^k \varepsilon_l (-a+i)^l.$$

Furthermore $[x]$ will denote the integer part of the real number x .

Let us start with the problem of how to find the digits of a given $z \in \mathbb{Z}[i]$ in base $(-a \pm i)$ representation. Gilbert refers in [14] on two strategies, one of them being the usual chain of divisions. The other one, which he calls the 'polynomial method', is a clearing algorithm using the minimal polynomial for $b = -a + i$. During the description of this algorithm we shall use the term 'overflow' to describe the fact that the actual digit is not in the range $0, \dots, a^2$. This overflow will be cleared by subtracting an appropriate multiple of $a^2 + 1$ and using the minimal polynomial of b (which involves $a^2 + 1$ as a coefficient). Thus the overflow is cleared by carrying it to the next digit.

In the sequel we present an alternative formulation of the latter method, the advantage of which is to give an explicit recursion for the digits.

PROPOSITION 2.1. *For $z = z_1 + iz_2 \in \mathbb{Z}[i]$ (with $z_1, z_2 \in \mathbb{Z}$) let $s_k(z) \in \mathbb{Z}$ be defined by the recurrence*

$$s_{k+1}(z) = -2a \frac{s_k(z)}{a^2+1} - \frac{s_{k-1}(z)}{a^2+1} \quad \text{for } k \geq 0, \quad (2.1)$$

$$s_{-1}(z) = -z_2(a^2+1), \quad s_0(z) = z_1 + az_2.$$

Then

$$z = \sum_{k \geq 0} \varepsilon_k(z) (-a+i)^k$$

with

$$\varepsilon_k(z) = s_k(z) \pmod{a^2+1}. \quad (2.2)$$

If $b = -a - i$ is taken as basis, the initial conditions have to be replaced by

$$s_{-1}(z) = z_2(a^2 + 1), \quad s_0(z) = z_1 - az_2. \quad (2.3)$$

Proof. We consider the case $b = -a + i$, the case $b = -a - i$ being totally similar. Since

$$z = z_1 + iz_2 = z_2b + z_1 + z_2a = -b \frac{s_{-1}(z)}{a^2 + 1} + s_0(z), \quad (2.4)$$

we have that $\varepsilon_0(z) \equiv s_0(z) \pmod{-a+i}$ and thus coincides with the last digit in the representation of $z_1 + z_2a$ in base $-a+i$. Now $a^2 + 1 = b \cdot \bar{b}$, so that

$$\varepsilon_0(z) = z_1 + z_2a \pmod{a^2 + 1} = s_0(z) \pmod{a^2 + 1}. \quad (2.5)$$

(For odd a we have that $\gcd(b, \bar{b}) = 1 + i$, and we use the fact that 0 and 1 represent the only residue classes mod 2 with *real* elements.) Let us now assume by induction that

$$\frac{z - \sum_{j=0}^k \varepsilon_j(z) (-a+i)^j}{b^{k+1}} = -b \frac{s_k(z)}{a^2 + 1} + s_{k+1}(z) \quad (2.6)$$

for fixed $k \geq -1$ (the sum $\sum_{j=0}^{-1}$ is defined to be 0). Then $\varepsilon_{k+1}(z) = s_{k+1}(z) \pmod{a^2 + 1}$. Observing that

$$m(x) = x^2 + 2ax + (a^2 + 1) \quad (2.7)$$

is the minimal polynomial of $b = -a + i$, we have

$$s_{k+1}(z) = \varepsilon_{k+1}(z) + \frac{s_{k+1}(z)}{a^2 + 1} \cdot (a^2 + 1) = \varepsilon_{k+1}(z) - b \cdot 2a \frac{s_{k+1}(z)}{a^2 + 1} + b \frac{s_{k+1}(z)}{a^2 + 1},$$

so that the right-hand side of (2.6) reads

$$\varepsilon_{k+1}(z) + b \cdot -2a \frac{s_{k+1}(z)}{a^2 + 1} - \frac{s_k(z)}{a^2 + 1} - b \frac{s_{k+1}(z)}{a^2 + 1} = \varepsilon_{k+1}(z) + b \cdot s_{k+2}(z) - b \frac{s_{k+1}(z)}{a^2 + 1}.$$

Thus (2.6) remains valid for k replaced by $k+1$, and the proposition is proved.

We remark here that the procedure to obtain the digits as described above is just a translation of the usual algorithm to obtain the digits with respect to some positive integer basis. The procedure determines the residue class of the overflow modulo $-a+i$ and uses the identity $a^2 + 1 = -b^2 - 2ab$ to carry it to the next significant digit.

A similar reasoning, using the fact that

$$a^2 + 1 = b^3 + (2a-1)b^2 + (a-1)^2b = (1, (2a-1), (a-1)^2, 0)_{-a+i}, \quad (2.8)$$

that is, replacing $m(x)$ by the polynomial

$$m_1(x) = x^3 + (2a-1)x^2 + (a-1)^2x - (a^2 + 1) = (x-1)m(x), \quad (2.9)$$

allows us to eliminate an overflow by adding the respective multiple of $(1, (2a-1), (a-1)^2)_{-a+i}$ to the three positions to the left of the digit under consideration.

The corresponding recurrence relation reads as follows. Observe that now the coefficients of the recurrence are positive, which will be preferable for some applications.

PROPOSITION 2.2. *For $z = z_1 + iz_2 \in \mathbb{Z}[i]$ (with $z_1, z_2 \in \mathbb{Z}$) let $\sigma_k(z) \in \mathbb{Z}$ be defined by the recurrence*

$$\begin{aligned}\sigma_{k+1}(z) &= (a-1)^2 \frac{\sigma_k(z)}{a^2+1} + (2a-1) \frac{\sigma_{k-1}(z)}{a^2+1} + \frac{\sigma_{k-2}(z)}{a^2+1}, \\ \sigma_{-2}(z) &= (a^2+1)z_2, \quad \sigma_{-1}(z) = 0, \quad \sigma_0(z) = z_1 + az_2.\end{aligned}\tag{2.10}$$

Then,

$$z = \sum_k \varepsilon_k(z) (-a+i)^k$$

with

$$\varepsilon_k(z) = \sigma_k(z) \pmod{a^2+1}.\tag{2.11}$$

(For $b = -a-i$, we have $\sigma_{-2}(z) = -(a^2+1)z_2$, $\sigma_{-1}(z) = 0$, $\sigma_0(z) = z_1 - az_2$.)

Proposition 2.2 allows the following interesting representation of the sum-of-digits function $v(z)$.

COROLLARY 2.3. *For any $z \in \mathbb{Z}[i]$ the sequence $(\sigma_k(z))$ from Proposition 2.2 is ultimately constant. Denoting the limit by $\sigma_\infty(z)$, this value is divisible by a^2+1 , and the sum-of-digits function $v(z)$ in base $b = -a+i$ satisfies*

$$v(z) = v(z_1 + iz_2) = z_1 + (a+1)z_2 - (a^2+2+2) \frac{\sigma_\infty(z)}{a^2+1}.\tag{2.12}$$

For base $b = -a-i$, the term $(a+1)z_2$ has to be replaced by $-(a+1)z_2$.

Proof. We know that the base $(-a+i)$ -representation of z has finite length [18, 19]. Therefore, using the last theorem, we have

$$a^2+1 \mid \sigma_k(z) \quad \text{for } k \geq k_0.\tag{2.13}$$

Under this condition, recurrence (2.10) reads

$$\sigma_k(z) = ((a-1)^2 \sigma_{k-1}(z) + (2a-1) \sigma_{k-2}(z) + \sigma_{k-3}(z)) \frac{1}{a^2+1}.\tag{2.14}$$

Since the roots of the characteristic equation of this recurrence are $1, b^{-1}, \bar{b}^{-1}$, the solution of this recurrence is given by

$$\sigma_k(z) = A + B \frac{1}{b^k} + C \frac{1}{\bar{b}^k} \quad \text{for } k > k_0$$

with some constants A, B, C . Therefore $\sigma_\infty(z) = \lim_{k \rightarrow \infty} \sigma_k(z) = A$ exists. Since $\sigma_k(z)$ is in \mathbb{Z} , the sequence must ultimately be constant and it follows from (2.14) that $\sigma_\infty(z) = \sigma_{k_0}(z)$.

In order to express the sum-of-digits function we argue as follows.

For any $M \geq 1$ we have, using (2.10),

$$\begin{aligned} \sum_{k=0}^M \sigma_k(z) &= \sigma_0(z) + (a-1)^2 \sum_{k=1}^M \frac{\sigma_{k-1}(z)}{a^2+1} + (2a-1) \sum_{k=1}^M \frac{\sigma_{k-2}(z)}{a^2+1} + \sum_{k=1}^M \frac{\sigma_{k-3}(z)}{a^2+1} \\ &= z_1 + az_2 + (a^2+1) \sum_{k=0}^M \frac{\sigma_k(z)}{a^2+1} \\ &\quad - (a^2+1) \frac{\sigma_M(z)}{a^2+1} - 2a \frac{\sigma_{M-1}(z)}{a^2+1} - \frac{\sigma_{M-2}(z)}{a^2+1} + \frac{\sigma_{-2}(z)}{a^2+1}. \end{aligned}$$

Therefore, for $M \rightarrow \infty$, we have

$$\sum_{k \geq 0} \sigma_k(z) - \frac{\sigma_k(z)}{a^2+1} (a^2+1) = z_1 + (a+1)z_2 - \frac{a^2+2a+2}{a^2+1} \sigma_\infty(z).$$

Observing that by Proposition 2.2 the sum on the left-hand side equals the sum of the digits of z , the proof is complete.

The case $b = -a-i$ is analogous.

The base $(-a+i)$ -representation of a given number can also be achieved by having an algorithmic approach to the addition of fixed quantities, for example, 1 or i , in this representation. This approach also allows us to get some interesting information on the behaviour of the sum-of-digits function.

For the addition of 1 in the special instance $a = 1$, that is, $b = -1+i$, Knuth [20] presents the following system of recurrences. If α is a finite string of zeroes and ones, let $(\alpha)_{-1+i}$ denote the number whose $(-1+i)$ -ary representation coincides with the string α . Furthermore, let α^P , α^{-P} , α^Q and α^{-Q} be the strings defined by

$$\begin{aligned} (\alpha^P)_{-1+i} &= (\alpha)_{-1+i} + 1, & (\alpha^{-P})_{-1+i} &= (\alpha)_{-1+i} - 1, \\ (\alpha^Q)_{-1+i} &= (\alpha)_{-1+i} + i, & (\alpha^{-Q})_{-1+i} &= (\alpha)_{-1+i} - i. \end{aligned} \tag{2.15}$$

Then these operations on strings obey the following rules for $x \in \{0, 1\}$:

$$\begin{aligned} (\alpha 0)^P &= \alpha 1, & (\alpha x 1)^P &= \alpha^Q x 0, & (\alpha 0)^Q &= \alpha^P 1, & (\alpha 1)^Q &= \alpha^{-Q} 0, \\ (\alpha x 0)^{-P} &= \alpha^{-Q} x 1, & (\alpha 1)^{-P} &= \alpha 0, & (\alpha 0)^{-Q} &= \alpha^Q 1, & (\alpha 1)^{-Q} &= \alpha^{-P} 0. \end{aligned} \tag{2.16}$$

This system of recurrences corresponds to the following *automaton* ('transducer', see, for example, [4, 21]).

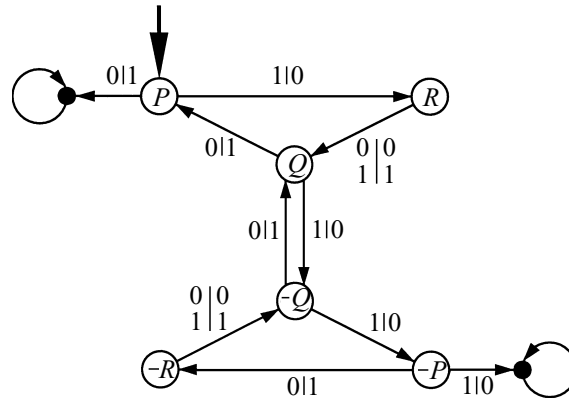

FIG. 1

If we want to add 1, that is, perform the operation P , we start at state (node) P . The automaton reads the digits from right to left. The notation $j|k$ means that the automaton reads j and outputs k , and moves to the according state. The automaton has two accepting states (marked by ‘●’). The meaning is that the remaining digits (to the left) are simply copied. The auxiliary nodes R and $-R$ could be suppressed if we allowed two digits to be read at the same time.

Observe that the ‘meaning’ of each state is just the actual carry that still has to be processed. So it is not hard to construct such an automaton for the addition of an arbitrary constant. We just take care about the possible carries, and connect them accordingly. It is easy to see that in each case there are only a finite number of possibilities. This also demonstrates that we can use this automaton to add i ; we just start in state Q . The meaning of R is to add $-1-i$, while $-R$ adds $1+i$. More formally,

$$\begin{aligned} (\alpha^R)_{-1+i} &= (\alpha)_{-1+i} - 1 - i, & (\alpha^{-R})_{-1+i} &= (\alpha)_{-1+i} + 1 + i, \\ (\alpha^R)_{-1+i} &= (\alpha)_{-1+i} - 1 - i, & (\alpha^{-R})_{-1+i} &= (\alpha)_{-1+i} + 1 + i. \end{aligned} \quad (2.17)$$

It is easy to modify the automaton for general $b = -a+i$ (see Figure 2), if we adjust the operations P , Q and R to denote addition of

$$\begin{aligned} 1 &= (1)_{-a+i}, & a-1+i &= (1(2a-1))_{-a+i}, \\ -a-i &= \frac{a^2+1}{-a+i} = (1(2a-1)(a-1)^2)_{-a+i}, \end{aligned} \quad (2.18)$$

respectively, and use $-P$, $-Q$ and $-R$ to denote the inverse operations. (It is somehow surprising that the number of states is independent of a .)

We now state an immediate consequence of the structure of the automaton, which shows an interesting difference to real number systems.

PROPOSITION 2.4. *Let c be a fixed complex integer, then $v(z+c) - v(z)$ attains only finitely many values, for example, $v(z+1) - v(z) \in \{-(a+1)^2, 1\}$ and $v(z-a-i) - v(z) \in \{-2a-1, a^2+1\}$. For the difference, in general, the following estimate holds*

$$|v(z+x+iy) - v(z)| \leq \begin{cases} 3|y| + 4|x+y| & \text{for } a = 1, \\ (a^2+1)|y| + (a+1)^2|x+ay| & \text{for } a \geq 2. \end{cases} \quad (2.19)$$

Proof. It clearly suffices to consider $c = 1$ and $c = -a-i$. First notice that on every edge of the automaton the value of the sum-of-the-digits, which has been computed up to that time, is changed by a fixed amount. When the automaton ends up in an accepting state, then the sum-of-digits is not changed any more. It is an easy exercise of tracing all the possible paths leading from P (respectively, R) to one of the accepting states, to see that there are only two possible values for the difference $v(z+1) - v(z)$ (respectively, $v(z-a-i) - v(z)$).

For general $c = x+iy$ we split the difference $v(z+c) - v(z)$ into several parts according to the value of c . We shall show this procedure for the case $y < 0$ and $x > -ay$; all the other cases are similar. In this case we write $x+iy = -y(-a-i) + (x+ay)$ and proceed as follows:

$$\begin{aligned} v(z+c) - v(z) &= v(z+c) - v(z+a+i+c) + v(z+a+i+c) - v(z+2(a+i)+c) + \cdots \\ &\quad + v(z-(y+1)(a+i)+c) - v(z-y(a+i)+c) + v(z-y(a+i)+c) \\ &\quad - v(z-y(a+i)+c-1) + \cdots + v(z-y(a+i)+c-x-ay+1) - v(z). \end{aligned}$$

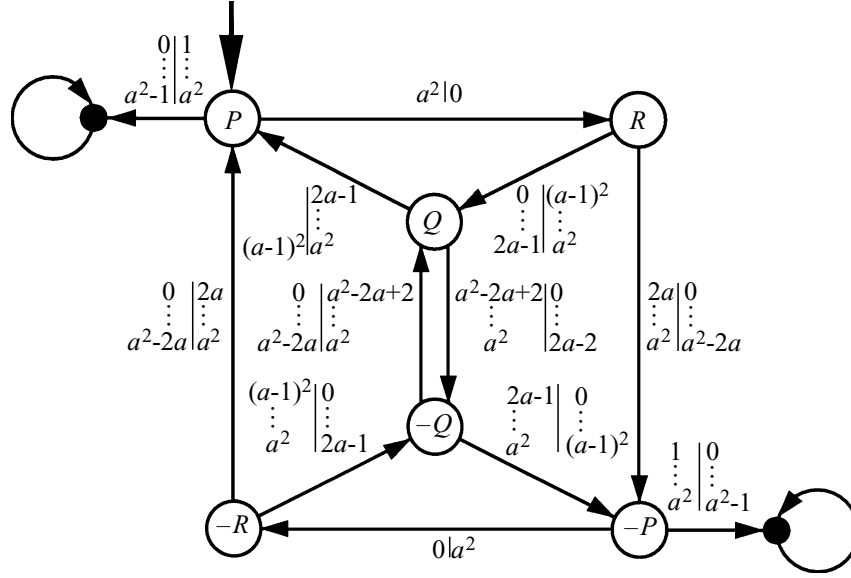

FIG. 2.

Each of the differences on the right-hand side can take only two values, thus the sum of all these differences can take only finitely many values. It is just a matter of counting the number of terms in the above sum to obtain (2.19).

In the following we want to concentrate on periodicity properties of a fixed digit $\varepsilon_k(z)$ in $z = \sum_k \varepsilon_k(z)(-a+i)^k$, if z runs, for example, through the natural numbers (analogous results hold if z runs through any arithmetic progression starting at 0). Our result holds for even a . For $a = 1$ the occurring digit patterns can be described explicitly, cf. Section 4.

The automaton reads the digit of m starting with the digit ε_0 and produces the digits of $m+1$, one at each step. Thus the $k+1$ rightmost digits of m , namely $\varepsilon_k(m) \dots \varepsilon_0(m)$, depend only on the digits $\varepsilon_k(m-1) \dots \varepsilon_0(m-1)$ of $m-1$. Since the effect of addition-by-one on the last $k+1$ digits is a mapping from $\{0, \dots, a^2\}^{k+1}$ to itself, it is a simple observation that $(\varepsilon_k(m) \dots \varepsilon_0(m))_{m \geq 0}$ is a periodic sequence in $\{0, \dots, a^2\}^{k+1}$ with period at most $(a^2+1)^{k+1}$. In order to determine the exact length of the period, we look for the smallest number $m > 0$ whose $k+1$ rightmost digits are again $0 \dots 0$, that is, the smallest $m > 0$ divisible by $(-a+i)^{k+1}$. Now

$$(-a+i)^{k+1} | m \quad \text{implies that} \quad (-a-i)^{k+1} | \bar{m} = m,$$

and because $\gcd(-a+i, -a-i) = 1$ in $\mathbb{Z}[i]$ for even a , this yields

$$(-a+i)^{k+1}(-a-i)^{k+1} = (a^2+1)^{k+1} | m.$$

Therefore the period is exactly $(a^2+1)^{k+1}$, and we proved the following.

THEOREM 2.5. *Let $z = \sum_k \varepsilon_k(z)(-a+i)^k$, with a an even positive integer. If z runs through the natural numbers m , then $(\varepsilon_k(m))_{m \geq 0}$ has period $(a^2+1)^{k+1}$.*

For a an odd positive integer and $k \geq 1$ it can be shown that the period is shorter than $(a^2+1)^{k+1}$, the exact value depending on the parity of k .

We shall conclude this section with some facts about the length of the representation of a complex integer. This mirrors some geometrical facts about the fundamental region

$$\mathcal{F} = \sum_{k=1}^{\infty} \frac{\varepsilon_k}{(-a+i)^k} \mid \varepsilon_k \in \{0, \dots, a^1\} \text{ ,}$$

which is considered in detail in [8, 9, 12, 13]. First we present a proof that the number of digits of a given number $z \in \mathbb{Z}[i]$ is $2 \log_{a^2+1} |z| + O(1)$ as $|z| \rightarrow \infty$, and we give some estimates for the $O(1)$ -term.

PROPOSITION 2.6. *Let $z = \sum_{k=0}^K \varepsilon_k (-a+i)^k$ with $\varepsilon_K \neq 0$. Then*

$$2 \log_{a^2+1} |z| - 2 \log_{a^2+1} \frac{a\sqrt{a^2+4}}{a^2+2} - 4 \leq K \leq 2 \log_{a^2+1} |z| - \log_{a^2+1} \left(1 - \frac{a\sqrt{a^2+4}}{a^2+2} \right) + 4.$$

Proof. The first step is to prove the following estimates for digital expressions. These are necessary, since consideration of just one single most significant digit would yield a trivial lower bound:

$$\min_{\varepsilon_3 \neq 0} \sum_{k=0}^3 \varepsilon_k (-a+i)^k = \sqrt{a^2+1}, \quad \max \sum_{k=0}^3 \varepsilon_k (-a+i)^k = a^3 \sqrt{a^2+1} \cdot \sqrt{a^2+4}. \quad (2.20)$$

For this purpose we write $w = w(\varepsilon_3, \varepsilon_2, \varepsilon_1, \varepsilon_0)$ for $\sum_{k=0}^3 \varepsilon_k (-a+i)^k$. In order to show that $|w| \geq \sqrt{a^2+1}$ if $\varepsilon_3 \neq 0$, we substitute

$$\begin{aligned} \varepsilon_1 &= a^2 - \varepsilon'_1, & \varepsilon_2 &= 2a - \varepsilon'_2, & \varepsilon_3 &= 1 + \varepsilon'_3, \\ 0 \leq \varepsilon'_1 &\leq a^2, & -a^2 + 2a &\leq \varepsilon'_2 \leq 2a, & 0 \leq \varepsilon'_3 &\leq a^2 - 1. \end{aligned}$$

The only possible combinations of $\varepsilon_0, \dots, \varepsilon_3$ for which $|w| \leq \sqrt{a^2+1}$ can hold are those for which $|\Re w| \leq a$ and $|\Im w| \leq a$. These conditions give the inequalities

$$-2a \leq -(a^3 - 3a)\varepsilon'_3 - (a^2 - 1)\varepsilon'_2 + a\varepsilon'_1 + \varepsilon_0 \leq 0, \quad (2.21)$$

$$1 - a \leq (3a^2 - 1)\varepsilon'_3 + 2a\varepsilon'_2 - \varepsilon'_1 \leq a + 1, \quad (2.22)$$

which, together with the inequalities $0 \leq \varepsilon_0, \varepsilon'_1 \leq a^2$, yield:

$$0 \leq (a^3 - 3a)\varepsilon'_3 + (a^2 - 1)\varepsilon'_2 \leq a^3 + a^2 + 2a, \quad (2.23)$$

$$1 - a \leq (3a^2 - 1)\varepsilon'_3 + 2a\varepsilon'_2 \leq a^2 + a + 1. \quad (2.24)$$

These inequalities give

$$0 \leq \varepsilon'_3 \leq \frac{a^4 + a^3 - a - 1}{a^4 + 2a^2 + 1}.$$

Hence we derive $0 \leq \varepsilon'_3 \leq 1$.

We now distinguish two cases.

Case (1): $\varepsilon'_3 = 1$. In this case the first inequality of (2.23) and the second of (2.24) yield

$$-\frac{a^3 - 3a}{a^2 - 1} \leq \varepsilon'_2 \leq -\frac{2a^2 - a - 2}{2a} \quad \text{for } a \geq 3.$$

This inequality has no integer solution for ε'_2 .

Case (2): $\varepsilon'_3 = 0$. In this case (2.21) and (2.22) together with $0 \leq \varepsilon_0 \leq a^2$ yield $-2a^2 - a \leq (a^2 + 1)\varepsilon'_2 \leq a^2 + a$. On the other hand the left hand side of (2.23) yields $\varepsilon'_2 \geq 0$. Thus we have $0 \leq \varepsilon'_2 \leq 1$.

In order to check the remaining possibilities for ε'_2 we again distinguish two cases.

Case (1): $\varepsilon'_2 = 0$. In this case we have $w = a + a\varepsilon'_1 + \varepsilon_0 + (-1 - \varepsilon'_1)i$, which yields $\Re w > a$ for $\varepsilon'_1 > 0$. Thus we are forced to take $\varepsilon'_1 = 0$ and $\varepsilon_0 = 0$, which results in $w = a - i = (1, 2a, a^2, 0)_{-a+i}$.

Case (2): $\varepsilon'_2 = 1$. In this case $|\Im w| \leq a$ is equivalent to $a - 1 \leq \varepsilon'_1 \leq 3a - 1$. For $\varepsilon'_1 \geq a$ we have $\Re w > a$, thus the only remaining possibility is $\varepsilon'_1 = a - 1$, where $\Re w \leq a$ forces $\varepsilon_0 = 0$. We have $w = 1 + ia = (1, 2a - 1, a^2 - a + 1, 0)_{-a+i}$.

The values 1 and 2 for a were checked with the help of the computer algebra system Maple.

In order to prove the second inequality (2.20), we write

$$w = -(a^3 - 3a)\varepsilon_3 + (a^2 - 1)\varepsilon_2 - a\varepsilon_1 + \varepsilon_0 + ((3a^2 - 1)\varepsilon_3 - 2a\varepsilon_2 + \varepsilon_1)i$$

and observe that the signs of the coefficients of the ε_k (for $k = 0, \dots, 3$) in the real and integer part are opposite. Thus the values of the ε_i which yield the maximum for $|z|$ can only be 0, a^2 . Checking the 16 possible values yields $w = a^3(-a+i)(a-2i) = (a^2, 0, a^2, 0)_{-a+i}$.

Now, by grouping the digits into groups of four and using the above estimates, we have

$$|z| \leq \sum_{l=0}^{\lfloor K/4 \rfloor} (\sqrt{(a^2+1)})^{K-4l} a^3 \sqrt{(a^2+1)} \cdot \sqrt{(a^2+4)} + \max \sum_{l=0}^{K-4\lfloor K/4 \rfloor - 1} \varepsilon_l (-a+i)^l,$$

where the last sum is understood to be 0, if $K \equiv 0 \pmod{4}$. Clearly the max term gets largest for $K \equiv 3 \pmod{4}$ and we can extend the sum to an infinite sum

$$|z| \leq \sum_{l=0}^{\infty} (\sqrt{(a^2+1)})^{K-4l} a^3 \sqrt{(a^2+1)} \cdot \sqrt{(a^2+4)} = (\sqrt{(a^2+1)})^{K+2} \frac{a \sqrt{(a^2+4)}}{a^2+2}. \quad (2.25)$$

On the other hand we have

$$|z| \geq \sum_{k=K-3}^K \varepsilon_k (-a+i)^k - \sum_{k=0}^{K-4} \varepsilon_k (-a+i)^k$$

from which we derive $|z| \geq (\sqrt{(a^2+1)})^{K-2} (1 - a\sqrt{(a^2+4)}/(a^2+2))$, by combining the first part of (2.20) and (2.25). Taking the logarithm yields the desired result.

From the above discussions it is clear that the Gaussian integers z which have ‘short’ (respectively, ‘long’) expansions correspond to points on the boundary of \mathcal{F} which have maximal (respectively, minimal) modulus. We give a description of an algorithm which produces approximations to these points with any prescribed accuracy (we restrict our discussion to the search for minimal points, because this is slightly more complicated, and the computation of the maximal points is similar).

Step 1. Let $z_0 := 1$ and $N := 1$.

TABLE 1

	Minimum	Maximum
$a = 2$	0.0782323733 0.0649797602 - 0.0435652958i	2.0495348269 -1.6995745761 - 1.1454428256i
$a = 3$	0.0446973085 0.0013007438 - 0.0446783779i	3.0886782509 -2.8617755988 - 1.1619697757i
$a = 4$	0.0264422548 -0.0248364342 + 0.0090743802i	4.0913140767 -3.9385737228 - 1.1074691437i

Step 2. Let $k := 2$.

Step 3. Find the minimum value m_N of

$$z_{N-1} + \frac{\varepsilon_N}{(-a+i)^N} + \frac{f}{(-a+i)^N},$$

where $\varepsilon_N \in \{0, \dots, a^2\}$ and f runs through all points on the boundary of the convex hull F_k of $\{\sum_{l=1}^k \delta_l (-a+i)^{-l} \mid \delta_l \in \{0, \dots, a^2\}\}$. If we have found the digit ε_N for which the minimum is attained, we look for the digit $\eta_N \neq \varepsilon_N$ for which the second smallest value \tilde{m}_N of the above expression is attained.

Step 4. If

$$\tilde{m}_N - m_N > \frac{a\sqrt{a^2+4}}{a^2+2} \cdot (\sqrt{a^2+1})^{-N-k}$$

then define $z_N := z_{N-1} + \varepsilon_N / (-a+i)^N$, $N := N+1$ and go to Step 2; or define $k := k+1$ and go to Step 3. Repeat this procedure until $(a\sqrt{a^2+4}/(a^2+2)) \cdot (\sqrt{a^2+1})^{1-N}$ is smaller than the prescribed accuracy.

The starting value $z_0 = 1$ originates from the fact that the minimal point on the boundary of \mathcal{F} lies on that part of $\partial\mathcal{F}$ which meets $1 + \mathcal{F}$. For computing the maximum by this procedure one has to start with $z_0 = 0$ and compute the largest and second largest values in every Step 3.

As was pointed out in the proof of Proposition 2.6, the main problem in finding precise lower (and upper) bounds for digital expressions is that this cannot be done by some digit-after-digit procedure as in the case of simple q -adic expansion. Thus we start by considering $k = 2$ digits at first in Step 2. Then we compute the minimum value m_N and the second smallest value \tilde{m}_N for the digital expression involving $k+1$ running digits in Step 3. Consideration of the points in the convex hull F_k is in order to cut down the number of points to be computed in this step. If the difference $\tilde{m}_N - m_N$ is greater than $(a\sqrt{a^2+4}/(a^2+2)) \cdot (\sqrt{a^2+1})^{-N-k}$ (this value comes from (2.25)), then it is impossible to get a smaller value for $|z|$ by a different choice of ε_N . Thus the actual value of ε_N has been found. If the inequality is not satisfied, we have to increase the number of digits k to be considered for a new execution of Step 3. The procedure has to be modified if there is more than one point of minimal modulus on the boundary of \mathcal{F} ; we did not encounter this (very unlikely) case when producing the table.

Table 1 gives the results of our computations of the extremal values, and the points of the boundary at which they are attained, for $a = 2, 3, 4$.

Our computations show that after four starting digits, which differ from 0 and a^2 , only these two digits occur. The question whether this is just by chance, is related to a diophantine approximation problem involving the argument of the limit point $z = \lim_{N \rightarrow \infty} z_N$ and the argument of $-a+i$. As there is nothing known about the arithmetical nature of z , this seems to be a difficult question.

REMARK. It is an immediate consequence of Theorem 2.5 that, if a is even, for any given string $\beta \in \{0, \dots, a^2\}^k$, there is exactly one natural number m with $0 \leq m < (a^2 + 1)^k$, whose k rightmost digits in base $(-a+i)$ -representation coincide with string β .

Our considerations from above show, roughly speaking, that about one half of these digits (namely the rightmost $\log_{a^2+1} m$ digits) are sufficient to identify m , if m is known to be in \mathbb{N} .

3. The sum-of-digits function in circles and angles

We consider the asymptotics of the sum-of-digits function in large circles. For notational convenience we restrict our considerations to the case $b = -2+i$. Clearly all the computations below could also be done in the general case. The following theorem shows that the behaviour of the summatory function is similar to the behaviour of the summatory function of the ordinary q -ary sum-of-digits function in intervals. The proof will make use of the rotational symmetry of the circle. In a second theorem we shall prove that the asymptotic contributions to this summatory function are uniformly distributed with respect to the argument. In this case there is no periodic second term.

Theorem 3.1. *We have*

$$S(N) = \sum_{|z|^2 < N} v(z) = 2\pi N \log_5 N + N\Phi(\log_5 N) + O((\sqrt{N}) \log N), \quad (3.1)$$

where Φ is a continuous periodic function of period 1.

Proof. The proof will make use of some geometric observations concerning the fundamental region \mathcal{F} discussed in [8].

We now write $N = 5^k x$ with $1 \leq x < 5$ and define the functions ε_l by

$$z = \sum_{l=-3}^{\infty} \frac{\varepsilon_l(z)}{(-2+i)^l} \quad \text{for } |z|^2 < 5.$$

There is some ambiguity in the definition of these functions which is discussed in [10], but we shall evaluate them only at points with unique value. The starting point -3 for the summation is due to the fact that all points in the interior of the circle $|z|^2 < 5$ have at most 4 digits in their ‘integer part’.

We are now able to write the summatory function of the sum-of-digits function in terms of the ε_l , namely,

$$S(5^k x) = \sum_{l=-3}^k \sum_{\substack{|z|^2 < x \\ z \in \mathcal{F}_k}} \varepsilon_l(z),$$

where \mathcal{F}_k is the set $\{z = \sum_{l=-3}^k \varepsilon_l / (-2+i)^l\}$. Our next step is to rewrite the last sum as

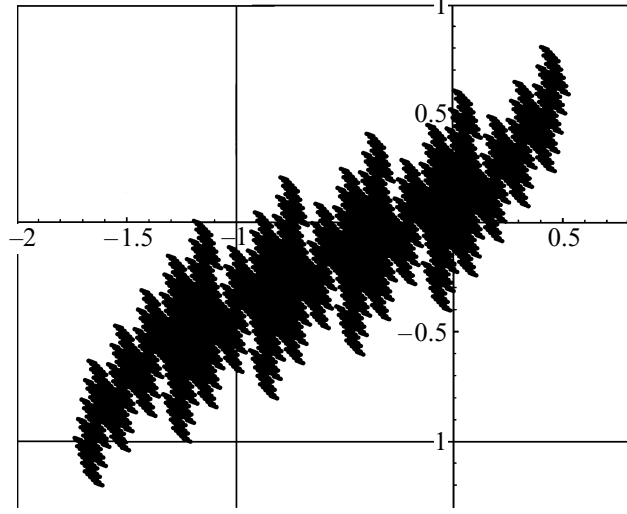
FIG. 3. The Fundamental Region \mathcal{F} .

an integral as in Delange's approach to the summatory function of the ordinary sum-of-digits function (compare Section 1),

$$\sum_{\substack{|z|^2 < x \\ z \in \mathcal{F}_k}} \varepsilon_l(z) 5^{-k} = \int_{|z|^2 < x} \varepsilon_l(z) d\lambda_2(z) + O(5^{-k/2}),$$

where λ_2 denotes the two-dimensional Lebesgue-measure. This observation is due to the fact that the functions $\varepsilon_l(z)$ are constant on each 'piece' of the tiling of the plane by translates of $(-2+i)^{-k} \mathcal{F}$. The O -term originates from the $O(5^{k/2})$ pieces of the tiling which intersect the circle $|z|^2 = x$. We now note that

$$\varepsilon_l(z) d\lambda_2(z) = 2 \cdot 5^{-m} \quad \text{for } m < l \text{ and for all } \zeta \in \mathcal{F}_{m-1}.$$

This is an immediate consequence of the definition of \mathcal{F} .

Therefore we can write

$$S(5^k x) = 2\pi(k+4)x5^k + 5^k \sum_{l=-3}^k \int_{|z|^2 < x} (\varepsilon_l(z) - 2) d\lambda_2(z) + O(k5^{k/2}). \quad (3.2)$$

Then the only contribution to the integrals originates from those translates of $(-2+i)^{-l} \mathcal{F}$ which intersect the circle $|z|^2 = x$; these translates cover an area of $O(5^{-l/2})$, which yields

$$\int_{|z|^2 < x} (\varepsilon_l(z) - 2) d\lambda_2(z) = O(5^{-l/2}).$$

Note further that each of these integrals is a continuous function with respect to x . Let now

$$\Psi(x) = \sum_{l=-3}^{\infty} \int_{|z|^2 < x} (\varepsilon_l(z) - 2) d\lambda_2(z). \quad (3.3)$$

By the above arguments Ψ is continuous and

$$\Psi(5) = 5\Psi(1) + 10\pi. \quad (3.4)$$

Thus we have $S(5^k x) = 2\pi(k+4)x5^k + 5^k\Psi(x) + O(k5^{k/2})$. Denoting the fractional part of x by $\{x\}$ let $\Phi(z) = 8\pi + 5^{-\{x\}}\Psi(5^{\{x\}}) - 2\pi\{x\}$ and observe that $\Phi(0) = \Phi(1) = \Phi(2) = \dots$ is a consequence of (3.4). Thus Φ is a continuous periodic function and we have

$$S(N) = 2\pi N \log_5 N + N\Phi(\log_5 N) + O((\sqrt{N}) \log N).$$

REMARK. Notice that differentiability of $\Psi(x)$ (and as a consequence differentiability of $\Phi(x)$) would follow, if one could prove that every circle $|z|^2 = x$ meets the boundary of \mathcal{F} in a set of (linear) measure 0. This is plausible but it seems to be difficult to prove.

Figure 4 shows a plot of the function $(1/N)S(N) - 2\pi \log_5 N$ against $\{\log_5 N\}$. As remarked above it seems to be plausible that all the small peaks disappear and the function becomes differentiable in the limit.

The next theorem will show that the contributions to the main term in (3.1) are uniformly distributed with respect to the argument.

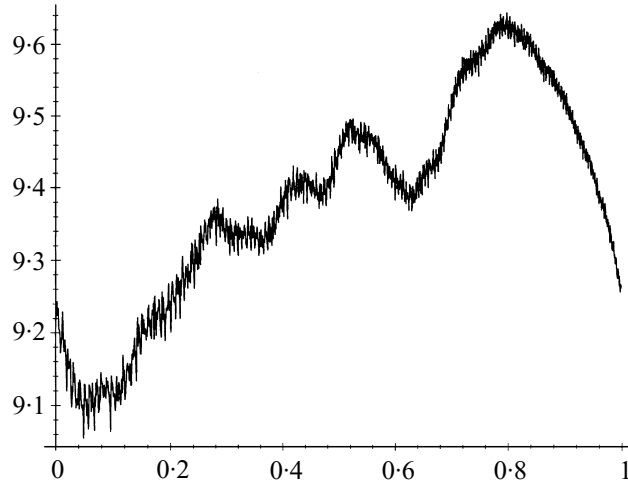

FIG. 4

THEOREM 3.2. *Let A be an interval mod 2π . Then*

$$S_A(N) = \sum_{\substack{|z|^2 < N \\ \arg z \in A}} v(z) = \lambda(A)N \log_5 N + o(N \log N), \quad (3.5)$$

where λ is the usual Lebesgue measure. In this case there is no periodicity in the second term.

Proof. We first consider the Dirichlet generating functions

$$f_k(s) = \sum_{z \in \mathbb{Z}[i] \setminus \{0\}} \frac{v(z) e^{ik \arg z}}{|z|^{2s}} \quad \text{for integer } k.$$

Our first objective is an analytic continuation of these functions and information about the location of singularities. For this purpose we make use of the functional equation $v((-2+i)z+l) = v(z)+l$ for $l = 0, \dots, 4$. This yields

$$\begin{aligned} f_k(s) &= \frac{e^{ik \arg(-2+i)}}{5^s} f_k(s) + \sum_{l=1}^4 \sum_{z \in \mathbb{Z}[i]} \frac{(v(z)+l)e^{ik \arg((-2+i)z+l)}}{|(-2+i)z+l|^{2s}} \\ &= \frac{e^{ik \arg(-2+i)}}{5^{s-1}} f_k(s) \\ &\quad + \frac{e^{ik \arg(-2+i)}}{5^s} \sum_{l=1}^4 \sum_{z \in \mathbb{Z}[i] \setminus \{0\}} \frac{v(z)e^{ik \arg z}}{|z|^{2s}} \frac{e^{ik \arg(1+l/(-2+i)z)}}{|1+l/(-2+i)z|^{2s}} - 1 \end{aligned} \quad (3.6)$$

$$+ 10 \frac{e^{ik \arg(-2+i)}}{5^s} \sum_{z \in \mathbb{Z}[i] \setminus \{0\}} \frac{e^{ik \arg z}}{|z|^{2s}} + \sum_{l=1}^4 l^{1-2s} \quad (3.7)$$

$$+ \frac{e^{ik \arg(-2+i)}}{5^s} \sum_{l=1}^4 l \sum_{z \in \mathbb{Z}[i] \setminus \{0\}} \frac{e^{ik \arg z}}{|z|^{2s}} \frac{e^{ik \arg(1+l/(-2+i)z)}}{|1+l/(-2+i)z|^{2s}} - 1. \quad (3.8)$$

We now need growth information for $f_k(\sigma+it)$ for some $\sigma < 1$; this is done by estimating the growth of the Dirichlet series (3.6) and (3.8). For this purpose we note that

$$\frac{e^{ik \arg(1+l/(-2+i)z)}}{|1+l/(-2+i)z|^{2s}} - 1 \leq \min \{2, 8 \frac{|k|+|s|}{|z|}\}$$

for $s = \sigma+it$ and $\frac{1}{2} < \sigma \leq 1$. Thus we can estimate the modulus of the first series by

$$\sum_{|z| < 8(|t|+|k|)} \frac{4 \log_5 |z|}{|z|^{2\sigma}} + \sum_{|z| \geq 8(|t|+|k|)} \frac{16|t| \log_5 |z|}{|z|^{2\sigma+1}} = O_k(|t|^{2-2\sigma} \log |t|)$$

and by a similar calculation we obtain the bound $O_k(|t|^{2-2\sigma})$ for the second series.

The Dirichlet series (3.7)

$$\zeta_m(s) = \sum_{z \in \mathbb{Z}[i] \setminus \{0\}} \frac{e^{4im \arg z}}{|z|^{2s}} \quad \text{for } k = 4m$$

is a Hecke L-series (the function is 0 if $k \not\equiv 0 \pmod{4}$), which can be analytically continued to the whole complex plane and is analytic for $m \neq 0$ (cf. [24, 17]). It is known that $\zeta_m(\sigma+it) = O(|t|^{2-2\sigma})$ for $0 < \sigma < 1$. (This could be obtained in the same way as above. Much more subtle estimates are known, but we do not need such deep results here, cf. [24].) The above arguments yield the analytic continuation of $f_k(s)$ to $\Re s > \frac{1}{2}$ by

$$f_k(s) = \frac{1}{1 - e^{ik \arg(-2+i)} 5^{1-s}} \Xi_k(s),$$

where the Dirichlet-series $\Xi_k(s)$ is given as the sum of (3.6), (3.7) and (3.8) and satisfies a growth condition $\Xi_k(\sigma+it) = O(|t|^{2-2\sigma} \log |t|)$. Thus for $k \neq 0$ the functions $f_k(s)$ have simple poles at the points

$$s = 1 + i(k \arg(-2+i) + 2\pi n) / \log 5 \quad \text{with } n \in \mathbb{Z},$$

which implies (by the Mellin–Perron summation formula) that

$$\sum_{|z|^2 < x} v(z) e^{ik \arg z} \left(1 - \frac{|z|^2}{x}\right) = x^{1+ik \arg(-2+i)/\log 5} F_k(\log_5 x) + O(x^{3/4}),$$

where the Fourier coefficients of F_k are expressible by values of Ξ_k and the Fourier

series is absolutely and uniformly convergent by the growth information derived above (F_k is therefore continuous).

In order to apply Weyl's criterion for the uniform distribution of sequences we have to prove that

$$\sum_{|z|^2 < x} v(z) e^{ik \arg z} = o(x \log x).$$

For this purpose we make use of the following lemma.

LEMMA 3.3. *Let $a: \mathbb{Z}[i] \rightarrow \mathbb{C}$ be an arithmetic function on the Gaussian integers satisfying $a(z) = O(\log |z|)$. Suppose further that for some $\varepsilon > 0$ and some real α we have*

$$\sum_{|z|^2 < x} a(z) \left(1 - \frac{|z|^2}{x}\right) = x^{1+i\alpha} F(\log x) + O(x^{1-\varepsilon}), \quad (3.9)$$

where F is a continuous periodic function. Then $\sum_{|z|^2 < x} a(z) = o(x \log x)$.

Proof. Let $1 < \beta < 2$ and subtract (3.9) from

$$\sum_{|z|^2 < \beta x} \beta - \frac{|z|^2}{x} = \beta^{2+i\alpha} x^{1+i\alpha} F(\log x + \log \beta) + O(x^{1-\varepsilon}),$$

which is obtained from (3.9) by inserting βx . This yields

$$\begin{aligned} \sum_{|z|^2 < x} a(z) &= \frac{x^{1+i\alpha}}{\beta-1} (\beta^{2+i\alpha} F(\log x + \log \beta) - F(\log x)) \\ &\quad - \frac{1}{\beta-1} \sum_{x \leq |z|^2 < \beta x} a(z) \left(\beta - \frac{|z|^2}{x} \right) + O\left(\frac{x^{1-\varepsilon}}{\beta-1}\right) \end{aligned}$$

and by setting $\beta = 1 + 1/\log x$ and using the continuity of F the result follows.

We now continue the proof of Theorem 3.2 by letting $a(z) = v(z) e^{ik \arg z}$ in the above lemma. Using Weyl's criterion for the uniform distribution of sequences (cf. [22]) completes the proof. Because the singularities of all the functions $f_k(s)$ are dense on the line $\Re s = 1$, there is no periodic second term in this case. (This argument could be made rigorous by using uniformly converging Fourier series approximating characteristic functions; such series are well known in the theory of uniform distribution, cf. [22].)

4. The sum-of-digits function along the real line

In this section we consider the summatory function of the sum-of-digits function for the first N natural numbers, that is,

$$S(N) = \sum_{0 \leq k < N} v(k). \quad (4.1)$$

We start with the following general estimate that holds for base $b = -a + i$, with $a = 1$ or a being an even positive integer.

PROPOSITION 4.1. *The summatory function $S(N)$ of the sum-of-digits function in base $b = -a + i$ (where $a = 1$ or $a \geq 2$ and even) of the first N natural numbers satisfies*

$$\frac{a^2}{2} \leq \liminf_{N \rightarrow \infty} \frac{S(N)}{N \log_{a^2+1} N} \leq \limsup_{N \rightarrow \infty} \frac{S(N)}{N \log_{a^2+1} N} \leq \frac{3a^2}{2}. \quad (4.2)$$

Proof. According to Proposition 2.6 the number of digits of the $(-a+i)$ -ary representation of N is asymptotically equivalent to $2 \log_{a^2+1} N$ (as $N \rightarrow \infty$). Now let $a \geq 2$ be even. According to Theorem 2.5 asymptotically the rightmost half of the representation contains each pattern of length $\sim \log_{a^2+1} N$ once, that is, the digits $0, 1, \dots, a^2$ occur equally often within this section of digits. This yields a contribution $\sim \frac{1}{2} a^2 \log_{a^2+1} N$ to $S(N)$. For the remaining leftmost $\sim \log_{a^2+1} N$ digits we use the trivial estimate that they must lie between 0 and a^2 , from which (4.2) follows immediately. For $a = 1$ the result follows from Theorem 4.2.

For $a = 1$ it follows from Theorem 4.2 that $S(N) \sim \frac{3}{4} N \log_2 N$. Numerical estimates support the conjecture that for even a the asymptotic result

$$S(N) \sim a^2 N \log_{a^2+1} N \quad \text{as } N \rightarrow \infty, \text{ } a \text{ fixed}$$

might hold. That is, the digits $0, 1, \dots, a^2$ seem to occur asymptotically equally often even within the leftmost ‘half’ of digits of the first N natural numbers. So far we have not been able to find a proof for this fact, even though we have tried very hard. Let us note here, that a similar geometric argument as in the proof of the asymptotic formula for large circles could be applied to this problem, but it would be necessary to know that the boundary $\partial \mathcal{F}$ does not intersect any straight line in a set of positive Lebesgue measure. This seems to be as unreachable as the differentiability of the remainder function in the circular case.

In the special case $b = -1 + i$ it is possible to derive the full asymptotic expansion for the mean of the sum-of-digits function of the natural numbers k with $0 < k < N$. The reason is that in this instance $b^4 = -4$, so that the system behaves like a system with integer base -4 , if we group together blocks of digits of length 4. Observing that

$$(0000)_{-1+i} = 0, \quad (0001)_{-1+i} = 1, \quad (1100)_{-1+i} = 2, \quad (1101)_{-1+i} = 3,$$

it turns out that the base $(-1+i)$ -representation of the natural numbers with digits $\{0, 1\}$ is given by their base (-4) -representation with digits $\{0, 1, 2, 3\}$ followed by a substitution of these digits by the blocks denoted above, and the sum of digits is equal in both systems.

It is known from [6] that the mean of the sum-of-digits function for negative integer bases can be analysed using the ‘Delange method’ (cf. [2]), which is based on real integration in a clever way. It is also possible to give a bijection to a positive basis (in our case to base 16), but then, again, a set of non-standard digits has to be used.

In the sequel we use a perhaps more elegant approach, again applying the Mellin–Perron summation formula as in the proof of Theorem 3.2. As cited in the Introduction, an extensive description of this technique is given in [5], but it is helpful to adjust the summation formulæ from that paper in such a way that they fit better to our present problem.

We shall use the following special form of the Mellin–Perron summation formula (cf. [1]) for Dirichlet generating functions resembling the Hurwitz ζ -function

$$\sum_{1 \leq k < N} \lambda_k(N-k) = \frac{1}{2\pi i} \int_{c-i\infty}^{c+i\infty} \sum_{k=1}^{\infty} \frac{\lambda_k}{(k-a)^s} \frac{(N-a)^{s+1}}{s(s+1)} ds \quad \text{for } 0 < a < 1. \quad (4.3)$$

For our purposes it will be convenient to use the above version with the parameter a adjusted in such a way that the function $\sum_k \lambda_k / (k-a)^s$ will be easier to handle.

By Proposition 2.4 we have

$$v(k) - v(k-1) \in \{1, -4\}. \quad (4.4)$$

Summation by parts gives us

$$S(N) = \sum_{0 \leq k < N} v(k) = \sum_{0 \leq k < N} (v(k) - v(k-1))(N-k), \quad (4.5)$$

and thus we are able to apply (4.3) as soon as we have precise information on the values of k that yield a difference -4 in (4.4).

Taking a look at the automaton in Figure 1 we realise that $v(k) - v(k-1) = -4$ if and only if the base $(-1+i)$ -representation of k ends with the digits

$$\begin{aligned} \text{Case 1} & \quad 000000(11010000)^*, \\ \text{Case 2} & \quad 00010000(11010000)^*, \end{aligned} \quad (4.6)$$

where (in a slight abuse of language) the asterisk denotes a (possibly empty) finite sequence of blocks of the specified shape.

Since k has to be a natural number it follows that Case 1 occurs if and only if the representation ends with

$$\begin{aligned} \text{Case 1a} & \quad 00000000(11010000)^*, \\ \text{Case 1b} & \quad 11000000(11010000)^*, \end{aligned}$$

if we are looking for full blocks of size 4.

This means that

$$k = l \cdot 16^{j+1} - 4 \frac{16^j - 1}{5} + \begin{cases} -4 \cdot 16^j & \text{Case 1b,} \\ -8 \cdot 16^j & \text{Case 1a,} \\ 0 & \text{Case 2} \end{cases} \quad (4.7)$$

with arbitrary $l \geq 1$ and $j \geq 0$. Altogether we have

$$v(k) - v(k-1) = 1 - 5\lambda_k, \quad (4.8)$$

where

$$\lambda_k = \begin{cases} 1 & \text{if } k \text{ satisfies (4.7),} \\ 0 & \text{if not.} \end{cases}$$

Inserting in (4.5) we find

$$S(N) = \sum_{0 \leq k < N} v(k) = \frac{1}{2}N(N-1) - 5(\Sigma_0 + \Sigma_1 + \Sigma_2), \quad (4.9)$$

where

$$\Sigma_i = \sum_k \lambda_k (N-k) \quad \text{for } k \text{ satisfying } k = 16^{j+1} \left(l - \frac{1}{20} - \frac{i}{4} + \frac{4}{5} \right), \quad (4.10)$$

for some $j \geq 0$ and $l \geq 1$, for $i = 0, 1, 2$.

It turns out that any of the sums Σ_i can be evaluated by the modified Mellin–Perron formula (4.3) if we set $a = \frac{4}{5}$. For Σ_0 we have

$$\sum_k \frac{\lambda_k}{(k - \frac{4}{5})^s} = \sum_{j \geq 0, l \geq 1} \frac{1}{16^{(j+1)l} (l - \frac{1}{20})^s} = \frac{\zeta(s, \frac{19}{20})}{16^s - 1}, \quad (4.11)$$

where $\zeta(s, a) = \sum_{k \geq 1} (k - a)^{-s}$ denotes the Hurwitz ζ -function. The sums Σ_1 and Σ_2 lead to similar expressions and we get the following general formula.

$$\Sigma_j = \frac{1}{2\pi i} \int_{c-i\infty}^{c+i\infty} \frac{\zeta(s, \frac{19}{20} - j/4) (N - \frac{4}{5})^{s+1}}{16^s - 1} \frac{ds}{s(s+1)} \quad \text{with } c > 1. \quad (4.12)$$

In order to get an alternative expression for Σ_j we first move the contour of integration to the left, as usual. We find the first order pole $s = 1$ of the integrand with

$$\text{Res}_{s=1} = \frac{1}{15} \frac{(N - \frac{4}{5})^2}{2} \quad \text{for } j = 0, 1, 2.$$

Altogether this contributes

$$-\frac{(N - \frac{4}{5})^2}{2} \quad (4.13)$$

to the term $-5(\Sigma_0 + \Sigma_1 + \Sigma_2)$ in (4.9).

The second order poles in $s = 0$ give rise to more involved terms. Since for $s \rightarrow 0$ we have

$$\begin{aligned} \zeta\left(s, \frac{19}{20} - \frac{j}{4}\right) &= -\frac{9}{20} + \frac{j}{4} + s \log \frac{\Gamma(\frac{19}{20} - j/4)}{\pi\sqrt{2}} + \dots, \\ \frac{1}{16^s - 1} &= \frac{1}{s \log 16} - \frac{1}{2} + \dots, \\ \frac{1}{s(s+1)} &= \frac{1}{s} - 1 + \dots, \\ (N - \frac{4}{5})^{s+1} &= (N - \frac{4}{5}) (1 + s \log(N - \frac{4}{5}) + \dots), \end{aligned}$$

we finally get the contribution

$$3(N - \frac{4}{5}) \log_{16}(N - \frac{4}{5}) + (N - \frac{4}{5}) \left[-\frac{3}{2} - \frac{3}{\log 16} - 5 \sum_{j=0}^2 \log_{16} \frac{\Gamma(\frac{19}{20} - j/4)}{\pi\sqrt{2}} \right] \quad (4.14)$$

to the term $-5(\Sigma_0 + \Sigma_1 + \Sigma_2)$.

For $s = \chi_k = 2k\pi i / \log 16$, where $k \in \mathbb{Z} \setminus \{0\}$, we have a series of first order poles that are equally distributed on the imaginary axis. As usual, these poles give a fluctuating contribution to the term under consideration, namely,

$$-5 \frac{N - \frac{4}{5}}{\log 16} \tau(\log_{16}(N - \frac{4}{5})), \quad (4.15)$$

where

$$\tau(x) = \sum_{k \neq 0} \frac{1}{\chi_k (\chi_k + 1)} \sum_{j=0}^2 \zeta\left(\chi_k, \frac{19}{20} - \frac{j}{4}\right) e^{2k\pi i x}, \quad (4.16)$$

is a continuous periodic function of period 1 and mean zero.

The remainder term in $S(N)$ is now

$$R(N) = -5 \cdot \frac{1}{2\pi i} \int_{c-i\infty}^{c+i\infty} \frac{(N-\frac{4}{5})^{s+1}}{(16^s-1)s(s+1)} \sum_{j=0}^2 \zeta \left(s, \frac{19}{20} - \frac{j}{4}\right) ds \quad \text{with } c < 0. \quad (4.17)$$

(We might take $c = -\frac{1}{4}$ for convenience.) For $\Re s < 0$ we have

$$\frac{1}{16^s-1} = - \sum_{m \geq 0} 16^{ms},$$

where the series converges absolutely, so that

$$R(N) = -5(N-\frac{4}{5}) \sum_{m \geq 0} I_m(N) \quad (4.18)$$

with

$$I_m(N) = \frac{1}{2\pi i} \int_{-1/4-i\infty}^{-1/4+i\infty} \frac{16^{ms}(N-\frac{4}{5})^s}{s(s+1)} \sum_{j=0}^2 \zeta \left(s, \frac{19}{20} - \frac{j}{4}\right) ds.$$

Moving the contour of the integral to the right we have to collect the residues at the first order poles $s = 0$ and $s = 1$ with negative sign and we find that

$$I_m(N) = \frac{3}{5} - \frac{3}{2} 16^m (N-\frac{4}{5}) + \frac{1}{2\pi i} \int_{c-i\infty}^{c+i\infty} \frac{16^{ms}(N-\frac{4}{5})^s}{s(s+1)} \sum_{j=0}^2 \zeta \left(s, \frac{19}{20} - \frac{j}{4}\right) ds \quad \text{with } c > 1. \quad (4.19)$$

The remaining integral $\tilde{I}_m(N)$ can now be evaluated explicitly by reading the Mellin–Perron summation formula (4.3) backwards. If we insert

$$x = \frac{1}{(N-\frac{4}{5})16^m}, \quad \lambda_k = 1, \quad \mu_k = k - \frac{1}{20} - \frac{j}{4} \quad \text{for } j = 0, 1, 2,$$

we find that

$$\tilde{I}_m(N) = \sum_{j=0}^2 \sum_{k \geq 1} f \left(\frac{k - \frac{1}{20} - j/4}{(N-\frac{4}{5})16^m} \right). \quad (4.20)$$

Now $f((k - \frac{1}{20} - j/4)/(N-\frac{4}{5})16^m) = 1 - (k - \frac{1}{20} - j/4)/(N-\frac{4}{5})16^m$ as long as $k - \frac{1}{20} - j/4 \leq (N-\frac{4}{5})16^m$, or, equivalently,

$$1 \leq k \leq (N-\frac{4}{5})16^m - \frac{1}{5} := \alpha(N, m) \quad (\text{which belongs to } \mathbb{N}). \quad (4.21)$$

Observing that $\sum_{j=0}^2 (\frac{1}{20} + j/4) = \frac{9}{10}$, we have

$$\tilde{I}_m(N) = 3\alpha(N, m) - \frac{3\alpha(N, m)(\alpha(N, m) + 1)}{2(N-\frac{4}{5})16^m} + \frac{9}{10} \frac{\alpha(N, m)}{(N-\frac{4}{5})16^m}.$$

With $(N-\frac{4}{5})16^m = \alpha(N, m) + \frac{1}{5}$ we finally get

$$\tilde{I}_m(N) = \frac{3\alpha(N, m)^2}{2(\alpha(N, m) + \frac{1}{5})}. \quad (4.22)$$

Going back to (4.19) it follows after a short calculation that

$$I_m(N) = \frac{3}{50} \frac{1}{\alpha(N, m) + \frac{1}{5}} = \frac{3}{50} \frac{1}{(N-\frac{4}{5})16^m}. \quad (4.23)$$

Therefore the series $\sum_{m \geq 0} I_m(N)$ can be computed explicitly and inserting in (4.18), we end up with

$$R(N) = \frac{8}{25}. \quad (4.24)$$

Since $R(N)$ was the remainder term in the expansion of $S(N)$, we have the following explicit formula (collecting the contributions (4.13), (4.14) and (4.15) and inserting in (4.19)).

THEOREM 4.2. *The summatory function $S(N) = \sum_{0 \leq k < N} v(k)$ of the sum-of-digits function in base $b = -1 + i$ is given by the exact formula*

$$S(N) = 3(N - \frac{4}{5}) \log_{16}(N - \frac{4}{5}) - (N - \frac{4}{5}) \frac{6}{5} + \frac{3}{\log 16} + 5 \sum_{j=0}^2 \log_{16} \frac{\Gamma(\frac{19}{20} - j/4)}{\pi \sqrt{2}} \\ - (N - \frac{4}{5}) \frac{5}{\log 16} \tau(\log_{16}(N - \frac{4}{5})) + \frac{6}{25}.$$

Here, $\tau(x)$ is a continuous periodic function of period 1 and mean zero which has the Fourier expansion (4.16).

Note added in proof. Since this paper was accepted for publication, J. M. Thuswaldner (*Bull. London Math. Soc.* 30 (1998) 37–45) has extended some of our results to more general number fields.

Acknowledgements. The authors want to thank Christiane Frougny for bringing several references to their attention. They are grateful to William J. Gilbert for sending them all his papers about complex number systems. Part of this work was done during the first author's visit at the Laboratoire Dynamique Stochastique et Algorithmique at the Université de Provence in Marseille. He wants to acknowledge the warm hospitality he encountered there and thank Pierre Liardet for helpful discussions concerning some dynamical aspects of complex positional number systems.

References

1. T. M. APOSTOL, *Introduction to analytic number theory* (Springer, Berlin, 1984).
2. H. DELANGE, 'Sur la fonction sommatoire de la fonction "Somme des Chiffres"', *Enseign. Math.* (2) 21 (1975) 31–47.
3. G. DOETSCH, *Handbuch der Laplace transformation* (Birkhäuser, Basel, 1950).
4. S. EILENBERG, *Automata, languages and machines*, vol. A (Academic Press, 1974).
5. P. FLAJOLET and L. RAMSHAW, 'A note on Gray Code and odd-even merge', *SIAM J. Comput.* 9 (1980) 142–158.
6. P. FLAJOLET, P. J. GRABNER, P. KIRSCHENHOFER, H. PRODINGER and R. F. TICHY, 'Mellin transform and asymptotics: digital sums', *Theoret. Comput. Sci.* 123 (1994) 291–314.
7. W. J. GILBERT, 'Radix representations of quadratic fields', *J. Math. Anal. Appl.* 83 (1981) 264–274.
8. W. J. GILBERT, 'Geometry of radix representations', *The geometric vein* (Springer, Berlin–New York, 1981) 129–139.
9. W. J. GILBERT, 'Fractal geometry derived from complex bases', *Math. Intelligencer* 4 (1982) 78–86.
10. W. J. GILBERT, 'Complex numbers with three radix representations', *Canad. J. Math.* 34 (1982) 1335–1348.
11. W. J. GILBERT, 'Arithmetic in complex bases', *Math. Mag.* 57 (1984) 77–81.
12. W. J. GILBERT, 'The fractal dimension of sets derived from complex bases', *Canad. Math. Bull.* 29 (1986) 495–500.
13. W. J. GILBERT, 'Complex bases and fractal similarity', *Ann. Sci. Math. Québec* 11 (1987) 65–77.
14. W. J. GILBERT, 'Gaussian integers as bases for exotic number systems', manuscript.
15. W. J. GILBERT, 'The division algorithm in complex bases', manuscript.

16. W. J. GILBERT and R. J. GREEN, 'Negative based number systems', *Math. Mag.* 52 (1979) 240–244.
17. H. HIDA, *Elementary theory of L-functions and Eisenstein series* (Cambridge University Press, 1993).
18. I. KÁTAI and B. KOVÁCS, 'Canonical number systems in imaginary quadratic fields', *Acta Math. Akad. Sci. Hungar.* 37 (1981) 159–164.
19. I. KÁTAI and J. SZABÓ, 'Canonical number systems for complex integers', *Acta Sci. Math. (Szeged)* 37 (1975) 255–260.
20. D. KNUTH, *The art of computer programming, 2: Seminumerical algorithms* (Addison–Wesley, London, 1981).
21. W. KUICH and A. SALOMAA, *Semirings, automata, languages* (Springer, Berlin, 1986).
22. L. KUIPERS and H. NIEDERREITER, *Uniform distribution of sequences* (J. Wiley and Sons, New York, 1974).
23. J.-L. MAUCLAIRE and L. MURATA, 'On q-additive functions, II', *Proc. Japan Acad. Ser. A Math. Sci.* 59 (1983) 441–444.
24. W. NARKIEWICZ, *Elementary and analytic theory of algebraic numbers* (Springer, Berlin, 1990).

P.G.

Institut für Mathematik A
Technische Universität Graz
Steyrergasse 30
8010 Graz
Austria

E-mail: grabner@weyl.math.tu-graz.ac.at

P.K.

Institut für Mathematik und Angewandte Geometrie
Montanuniversität Leoben
Franz-Josef-Strasse 18
8700 Leoben
Austria

E-mail: Peter.Kirschenhofer@unileoben.ac.at

H.P.

Institut für Algebra und Diskrete Mathematik
Technische Universität Wien
Wiedner Hauptstrasse 8–10
1040 Wien
Austria

E-mail: Helmut.Prodinger@tuwien.ac.at